

HD-COAXINATOR TVI™



ST-HDC2IRPTZ

QUICK START GUIDE



Quick Start Guide

About this Manual

This Manual is applicable to HD-COAXINATORTVI Speed Dome Cameras.

This Manual includes instructions for using and managing the product. Pictures, charts, images and all other information hereinafter are for description and explanation only. The information contained in this Manual is subject to change, without notice, due to firmware updates or other reasons. Please use this user manual under the guidance of professionals.

Regulatory Information

FCC Information

FCC compliance: This equipment has been tested and found to comply with the limits for a digital device, pursuant to part 15 of the FCC Rules. These limits are designed to provide reasonable protection against harmful interference when the equipment is operated in a commercial environment. This equipment generates, uses, and can radiate radio frequency energy and, if not installed and used in accordance with the instruction manual, may cause harmful interference to radio communications. Operation of this equipment in a residential area is likely to cause harmful interference in which case the user will be required to correct the interference at own expense.

FCC Conditions

This device complies with part 15 of the FCC Rules. Operation is subject to the following two conditions:

1. This device may not cause harmful interference.
2. This device must accept any interference received, including interference that may cause undesired operation

EU Conformity Statement



This product and - if applicable - the supplied accessories too are marked with "CE" and comply therefore with the applicable harmonized European standards listed under the Low Voltage Directive 2006/95/EC, the EMC Directive 2004/108/EC, the

RoHS Directive 2011/65/EU.



2012/19/EU (WEEE directive): Products marked with this symbol cannot be disposed of as unsorted municipal waste in the European Union. For proper recycling, return this product to your local supplier upon the purchase of equivalent new equipment, or dispose of it at designated collection points. For more information see:

www.recyclethis.info.



2006/66/EC (battery directive): This product contains a battery that cannot be disposed of as unsorted municipal waste in the European Union. See the product documentation for specific battery information. The battery is marked with this symbol, which may include lettering to indicate cadmium (Cd), lead (Pb), or mercury (Hg). For proper recycling, return the battery to your supplier or to a designated collection point. For more information see: www.recyclethis.info.



Safety Instruction

These instructions are intended to ensure that user can use the product correctly to avoid danger or property loss.

The precaution measure is divided into “Warnings” and “Cautions”

Warnings: Serious injury or death may occur if any of the warnings are neglected.

Cautions: Injury or equipment damage may occur if any of the cautions are neglected.

	
Warnings Follow these safeguards to prevent serious injury or death.	Cautions Follow these precautions to prevent potential injury or material damage.



Warnings

- All the electronic operation should be strictly compliance with the electrical safety regulations, fire prevention regulations and other related regulations in your local region.
- Please use the power adapter, which is provided by normal company. The standard of the power adapter is 24VAC±10% or 12VDC±10% (depending on models). The power consumption cannot be less than the required value.
- Do not connect several devices to one power adapter as adapter overload may cause over-heat or fire hazard.
- Please make sure that the power has been disconnected before you wire, install or dismantle the speed dome.
- When the product is installed on a wall or ceiling, the device shall be firmly fixed.
- If smoke, odors or noise rise from the device, turn off the power at once and unplug the power cable, and then please contact technical support.
- If the product does not work properly, please contact your dealer or technical support.
- Never attempt to disassemble the speed dome yourself. (Securitytronix shall not assume any responsibility for problems caused by unauthorized repair or maintenance.)



Cautions

- Do not drop the dome or subject it to physical shock, and do not expose it to high electromagnetism radiation. Avoid the equipment installation on vibration surfaces or places subject to shock (ignoring this can cause equipment damage).
- Do not place the dome in extremely hot, cold, dusty or damp locations, otherwise fire or electrical shock may occur. The operating temperature should be -22°F ~ 149°F(outdoor speed dome) and -14°F ~ 122°F (indoor speed dome).
- The dome cover for indoor use shall be kept from rain and moisture.
- Exposing the equipment to direct sun light, low ventilation or heat source such as heater or radiator is forbidden (ignoring this may cause a fire hazzard).

ST-HDC2IRPTZ QUICK START GUIDE

- Do not aim the speed dome at the sun or extra bright places. A blooming or smear may occur otherwise (which is not a malfunction however), and affecting the endurance of sensor at the same time.
- Please use the provided glove when open up the dome cover, avoid direct contact with the dome cover, because the acidic sweat of the fingers may erode the surface coating of the dome cover.
- Please use a soft and dry cloth when cleaning the inside and outside surfaces of the dome cover, do not use alkaline detergents.
- Please keep all wrappers after unpacking them for future use. In case of any failure, you need to return the speed dome to the factory with the original wrapper. Transportation without the original wrapper may result in damage on the speed dome and lead to additional costs.

Table of Contents

1 Installation	1
1.1 Connecting the Cables	1
1.2 DIP Switch Settings	2
1.2.1 5-inch Speed Dome Settings	2
1.2.2 5-inch IR Speed Dome Settings	4
1.2.3 7-inch IR Speed Dome Settings	7
1.2.4 Mini Speed Dome Settings	9
1.3 Wiring and Installation	10
1.3.1 Wiring	10
1.3.2 Installing the Bracket	10
1.3.3 Setting the DIP Switch	12
1.3.4 Installing the Speed Dome	12
2 In-door Mounting Applications	13
2.1 5-inch Speed Dome In-ceiling Mounting Applications	13
2.2 5-inch Speed Dome Ceiling Mounting Applications	15
2.2.1 Removing the Mounting Bracket	15
2.2.2 Wiring	16
2.2.3 Ceiling Mounting	16
2.3 Mini Speed Dome In-ceiling Mounting Applications	18
2.3.1 Mini Analog Speed Dome In-ceiling Mounting	18
2.3.2 Mini IR Speed Dome In-ceiling Mounting	20
2.4 Mini Speed Dome Ceiling Mounting Applications	22
2.4.1 Wiring	22
2.4.2 Ceiling Mounting	22
3 Application and Operations	25
3.1 System Application	25
3.2 Basic Operations	25
3.2.1 Configuring Patrol	26
3.2.2 Configuring Park Actions	29
4 Troubleshooting	31
4.1 Device Exceptions	31
4.2 PTZ Control Exceptions	31
4.3 Other Questions	31

1 Installation

Before you start:

Check the package contents and make sure that the device in the package is in good condition and all the assembly parts are included.

There are several ways to install the analog speed dome. The wall mounting is taken as an example below.

1.1 Connecting the Cables

Please turn the power off before connect the cables.

The cable interfaces of speed dome are shown in following figure. The cables are distinguished by different colors. The labels attached on the cables are for identification.

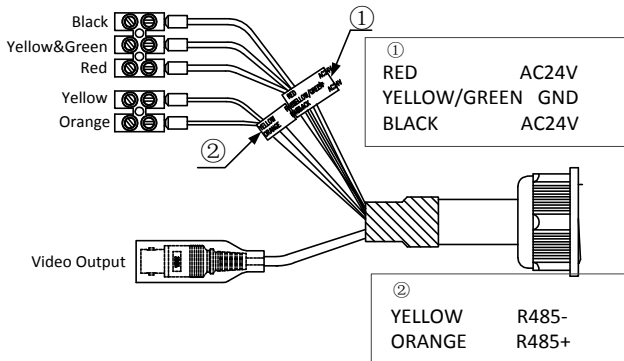

Figure 1-1 Cables of 7-inch IR Speed Dome

Table 1-1 Cables Description

Name	Description
AC24V	Power supply
RS485+/-	485 control
VIDEO	Coaxial and analog video output

ST-HDC2IRPTZ QUICK START GUIDE

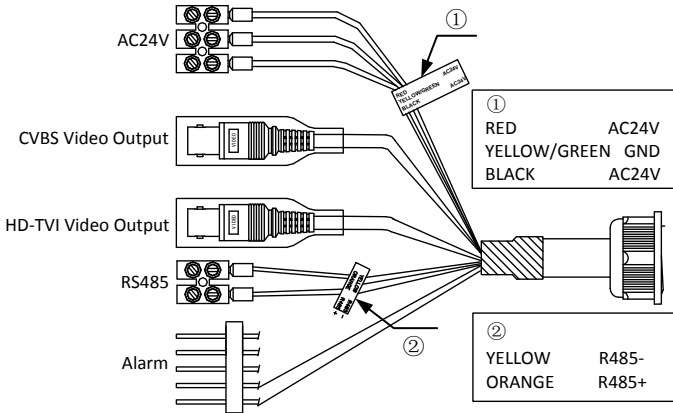

Figure 1-2 Cables for Other models

Dome Table 1-2 Cables Description

Name	Description
AC24V	Power supply
RS485+/-	485 control
CVBS VIDEO	SD analog video output
HD-TVI VIDEO	HD-TVI and coaxial video output
ALARM	2-ch alarm inputs and 1-ch alarm output

1.2 DIP Switch Settings

1.2.1 5-inch Speed Dome Settings

The DIP switch is used for setting the address and baudrate for the speed dome, with value ON=1 and OFF=0.

The SW1 switches from the first to the eighth are used to set the address. The SW2 switches are used to set the baudrate.



- The default dome address is 0. The default baudrate is 2400.
- The speed dome is self-adaptive to the Pelco-P, Pelco-D and Private-Code. You don't have to set the RS-485 control protocol by the DIP switch.

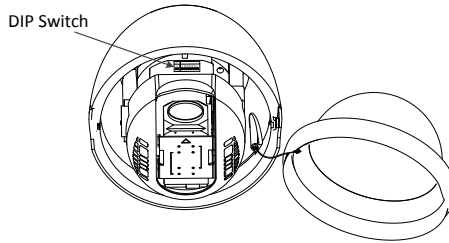

Figure 1-3 DIP Switch Settings for 5-inch Outdoor Speed Dome

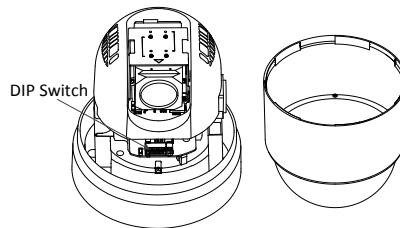

Figure 1-4 DIP Switch Settings for 5-inch Indoor Speed Dome



Figure 1-5 Enlarged View of DIP Switch

Address Settings

The SW1-switches from 1 to 8 are used for setting the address of speed dome. You can refer to Table 1-3 for details of setting the speed dome address to a specific number.

Table 1-3 Set the Dome Address

Switch No. Dome Address	1	2	3	4	5	6	7	8
0	OFF	OFF	OFF	OFF	OFF	OFF	OFF	OFF
1	ON	OFF	OFF	OFF	OFF	OFF	OFF	OFF
2	OFF	ON	OFF	OFF	OFF	OFF	OFF	OFF
3	ON	ON	OFF	OFF	OFF	OFF	OFF	OFF
...
255	ON	ON	ON	ON	ON	ON	ON	ON

Baudrate Settings

The number 1 and 2 SW2-switches are used for setting the baudrate of the speed dome. The baudrate can be 2400bps, 4800bps, 9600bps and 19200bps. The baudrate will be set as 2400bps by default if it is out of this range. Refer to the following table:

Table 1-4 Set the Baudrate of the Dome

Switch No. / Baudrate	1	2
2400	OFF	OFF
4800	ON	OFF
9600	OFF	ON
19200	ON	ON

1.2.2 5-inch IR Speed Dome Settings

The DIP switch is for setting the speed dome address, baudrate, protocol, etc., with value ON=1 and OFF=0. The switch label is on the back of the SWITCH cover as shown in Figure 1-6.

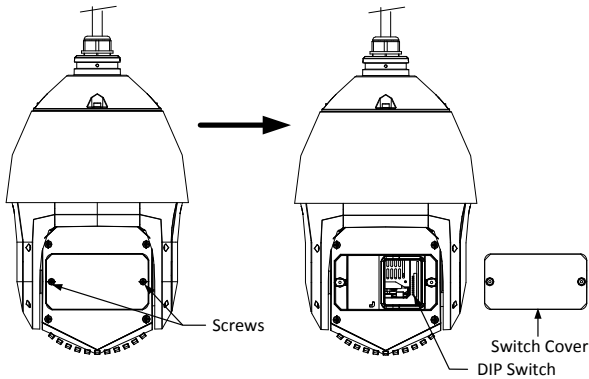

Figure 1-6 Position of DIP Switch for 5-inch IR Speed Dome



Figure 1-7 Enlarged View of DIP Switch



- For some certain models, the two individual DIP switches at the left side of the Figure 1-7 are supported for turning on/off the terminator; while other models are not supported.

ST-HDC2IRPTZ QUICK START GUIDE

- The default dome address is 0; the default baudrate is 2400; and the default value of the 120 Ω terminator is OFF.

Table 1-5 Switch Functions

Switch	Function
1 to 5	Set the address for the speed dome
6, 7	Set the baudrate for the speed dome
8, 9	Set the protocol for the speed dome
10	Reserved

The DIP switch is designed according to binary system. When the switch is ON, it stands for the number 1. When the switch is OFF, it stands for the number 0.

Example:

The switches from No. 1 to 5 are used to set the speed dome address. No. 1 is the lowest digit and No. 5 is the highest. Turning on all these 5 switches stands for the binary number 11111. Converting the 11111 to a decimal number is 31. So the speed dome address will be 31.

Address List

For convenient settings, refer to the following list to set the address for the speed domes.

Table 1-6 Dome Address

Switch Dome Address	1	2	3	4	5
0	OFF	OFF	OFF	OFF	OFF
1	ON	OFF	OFF	OFF	OFF
2	OFF	ON	OFF	OFF	OFF
3	ON	ON	OFF	OFF	OFF
4	OFF	OFF	ON	OFF	OFF
5	ON	OFF	ON	OFF	OFF
6	OFF	ON	ON	OFF	OFF
7	ON	ON	ON	OFF	OFF
8	OFF	OFF	OFF	ON	OFF
9	ON	OFF	OFF	ON	OFF
10	OFF	ON	OFF	ON	OFF
11	ON	ON	OFF	ON	OFF

ST-HDC2IRPTZ QUICK START GUIDE

Switch Dome Address	1	2	3	4	5
12	OFF	OFF	ON	ON	OFF
13	ON	OFF	ON	ON	OFF
14	OFF	ON	ON	ON	OFF
15	ON	ON	ON	ON	OFF
16	OFF	OFF	OFF	OFF	ON
17	ON	OFF	OFF	OFF	ON
18	OFF	ON	OFF	OFF	ON
19	ON	ON	OFF	OFF	ON
20	OFF	OFF	ON	OFF	ON
21	ON	OFF	ON	OFF	ON
22	OFF	ON	ON	OFF	ON
23	ON	ON	ON	OFF	ON
24	OFF	OFF	OFF	ON	ON
25	ON	OFF	OFF	ON	ON
26	OFF	ON	OFF	ON	ON
27	ON	ON	OFF	ON	ON
28	OFF	OFF	ON	ON	ON
29	ON	OFF	ON	ON	ON
30	OFF	ON	ON	ON	ON
31	ON	ON	ON	ON	ON

Baudrate List

For convenient settings, refer to the following list to set the baudrate for the speed dome. The baudrate will be set as 2400bps by default if it is out of this range.

Table 1-7 Baudrate

Switch Baudrate	6	7
2400	OFF	OFF

ST-HDC2IRPTZ QUICK START GUIDE

Switch Baudrate	6	7
4800	ON	OFF
9600	OFF	ON
19200	ON	ON

Protocol List

For convenient settings, refer to the following list to set the protocol for the speed dome.

Table 1-8 Protocol

Protocol	8	9
Self-adaptive	OFF	OFF
Pelco_D	OFF	ON
Pelco_P	ON	OFF
AD Manchester	ON	ON



The speed dome is self-adaptive to private protocol when the No.8 and 9 switches are both OFF.

1.2.3 7-inch IR Speed Dome Settings

Two DIP switches *SW1* and *SW2* are for setting the speed dome address, baudrate, protocol, etc., with value ON=1 and OFF=0. The switch label is on the back of the SWITCH cover as shown in Figure 1-8.

Each number of the switch represents a DIP value, ranging from 1 to 8 for the lowest to highest.

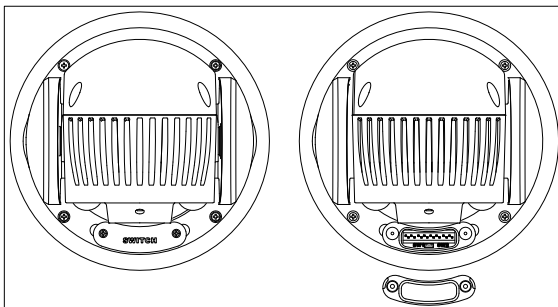

Figure 1-8 Label of DIP Switch for IR Speed Dome

ST-HDC2IRPTZ QUICK START GUIDE



Figure 1-9 Enlarged View of DIP Switch



The default dome address is 0; the default baudrate is 2400; and the default value of the 120Ω terminator is OFF.

Address Settings

The SW1 switch is used for setting the address of speed dome. You can refer to Table 1-9 for details of setting the speed dome address to a specific number.

Table 1-9 Set the Dome Address

Dome Address	1	2	3	4	5	6	7	8
0	OFF	OFF	OFF	OFF	OFF	OFF	OFF	OFF
1	ON	OFF	OFF	OFF	OFF	OFF	OFF	OFF
2	OFF	ON	OFF	OFF	OFF	OFF	OFF	OFF
3	ON	ON	OFF	OFF	OFF	OFF	OFF	OFF
...
255	ON	ON	ON	ON	ON	ON	ON	ON

Baudrate Settings

The No. 1, 2 and 3 of SW2 switch are for setting the baudrate of the speed dome, standing for 2400bps, 4800bps and 9600bps respectively. The baudrate will be set as 2400bps by default if it is out of this range. Refer to the following table:

Table 1-10 Set the Baudrate of the Dome

DIP Switch SW2-Baudrate Settings			
Baudrate	1	2	3
2400	ON	OFF	OFF
4800	OFF	ON	OFF
9600	ON	ON	OFF
19200	OFF	OFF	ON

Protocol Settings

The speed dome is self-adaptive to PELCO-D, PELCO-P and private protocol which cannot set by the DIP switches.

Communication Mode Settings

The No. 7 of SW2 switch is for setting the RS485 communication mode of the dome to simplex or half-duplex.

Table 1-11 Set Communication Mode of the Dome

DIP Switch SW2-Simplex/Half-duplex Settings	
Description	7
Simplex	OFF
Half-duplex	ON

Terminal Resistor Settings

The No. 8 of SW2 switch is used for turning on/off the 120Ω terminal resistor.

Table 1-12 Set Terminal Resistor

Switch No.	8
Description	
Turn on the resistor	OFF
Turn off the resistor	ON



The o-ring in the groove of the switch cover is for waterproofing.

1.2.4 Mini Speed Dome Settings

- **DIP Switch Location of Mini IR Speed Dome**

Steps:

1. Remove the switch cover as shown in Figure 1-10(left).
2. Set the address and baudrate with DIP switch.
3. Install the switch cover back to the speed dome.

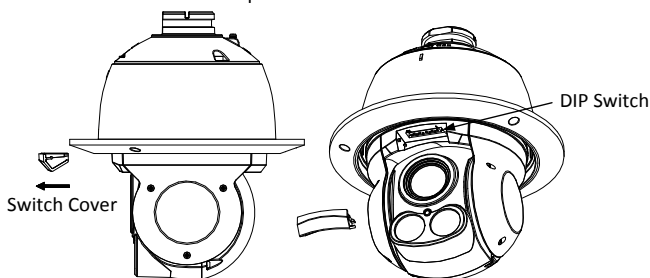

Figure 1-10 DIP Switch of Mini IR Speed Dome

● **DIP Switch Location of Mini Analog Speed Dome**

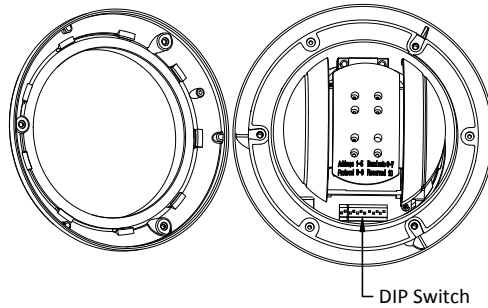

Figure 1-11 DIP Switch of Mini Analog Speed Dome

● **Setting DIP Switch**



Figure 1-12 Enlarged View of DIP Switch



The method of setting the DIP switch is the same with the one of 5-inch IR speed dome, please refer to the section 1.2.2 5-inch IR Speed Dome Settings for details.

1.3 Wiring and Installation

There are several ways to install the speed dome. The wall mounting is taken as an example below.

1.3.1 Wiring

The survey of the actual installation environment and planning the wiring is highly recommended before the accurate deployment of the wire is implemented in order to provide a safe and steady power supply and a reasonable wiring route.

- Get familiar with the installation environment before deploying the wire, including the wiring distance, surrounding, and electromagnetic interference and so on.
- Please choose the cable with nominal voltage higher than the actual voltage, to ensure a normal running in case of unsteady voltage.
- To protect the power cable and the signal transmitting cable from human tampering, you should pay attention to the protection and reinforcement of the cables.
- When deploying the wire, please do not tighten the wire or make the wires loose.

The wiring of the speed dome should be performed by professionals.

1.3.2 Installing the Bracket

Before you start:

ST-HDC2IRPTZ QUICK START GUIDE

Wall mounting is applicable to the indoor/outdoor solid wall construction. The following are the mandatory preconditions for wall mounting:

- The wall must be thick enough to install the expansion screws.
- Please make sure that the wall is strong enough to withstand more than 8 times the weight of the dome and the mount.

Steps:

1. Check whether the type of the bracket and the number of accessories are right, as shown in the figure below.

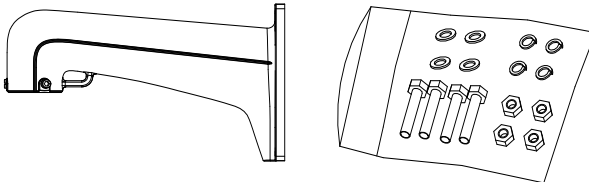

Figure 1-13 Wall Mount Bracket, Nuts and Flat Washers

2. Drill 4 screw holes in the wall according to the holes of the mount, and then insert M8 expansion screws (not supplied) into the mounting holes.

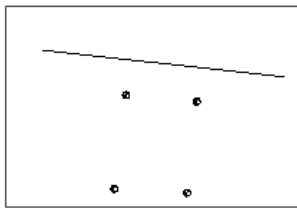

Figure 1-14 Drill Mounting Holes

3. Attach the wall mount to the wall by aligning the 4 screw holes of the mount with expansion screws on the wall.
4. Secure the wall mount with 4 hex nuts and washers.

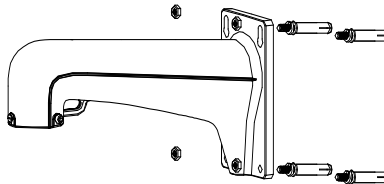

Figure 1-15 Secure the Mount

5. Install the speed dome to the mount. Please refer to *Section 1.3.4 Installing the Speed Dome* for installation details.



Follow the same instructions described above for the short-arm wall mounting. For outdoor applications, please adopt water-proofing measures. The short-arm wall mount is not recommended for outdoor applications.

1.3.3 Setting the DIP Switch

Set the address and baudrate for the speed dome. The default value of DIP switch is shown below:

- ◆ Address: 0
- ◆ Baudrate:2400
- ◆ Terminal Resistor: OFF

Please refer to the *Section 1.2 DIP Switch Settings* for DIP switch settings.

1.3.4 Installing the Speed Dome



The sketches of installing the speed dome are for reference only.

Steps:

1. Hang the safety rope to the speed dome and then hook to the mount as shown in Figure 1-16(left).
2. Route the cables of the speed dome through the wall mount.
3. Connect the corresponding video/power/RS-485 cables.
4. Install the speed dome to the mount, and secure the speed dome by rotating the speed dome clockwise.
5. Fasten the two lock screws with the Allen wrench, as shown in Figure 1-16(right).

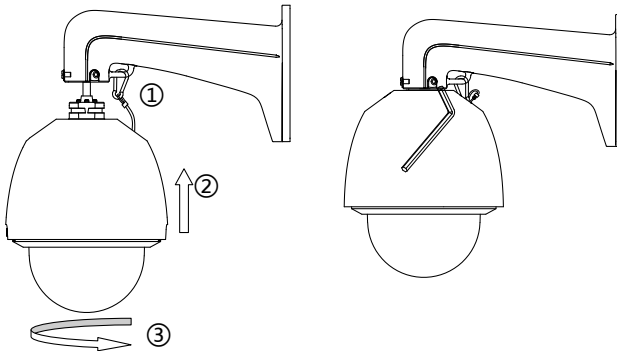

Figure 1-16 Install the Speed Dome

2 In-door Mounting Applications

Before you start:

- For cement wall, you need to use the expansion screw to fix the mount. The mounting hole of the expansion pipe on the wall should align with the mounting hole on the mount.
- For wooden wall, you can just use the self-tapping screw to fix the mount.

2.1 5-inch Speed Dome In-ceiling Mounting Applications

Before you start:

The in-ceiling mounting is applicable to the indoor ceiling construction. The followings are the mandatory precondition for mounting:

- The height of the space above the ceiling must be more than 250mm.
- The thickness of the ceiling must range from 5 to 40mm.
- The ceiling must be strong enough to withstand more than 4 times the weight of the dome and its accessories.

Steps:

1. Rotate the lower dome counterclockwise to separate it from the back box as shown in Figure 2-1.
2. Remove the protective lens cover, foam and sticker from the dome drive.
3. Set the address and baudrate for the analog speed dome. Please refer to the *Section 1.2.1 5-inch Speed Dome Settings* for DIP switch settings.
4. Attach lower dome to the back box, and rotate clockwise to secure it.

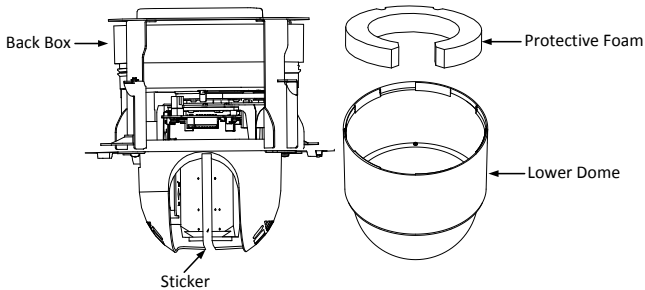

Figure 2-1 Remove the Protective Accessory

5. Drill a hole on the ceiling according to the drill template (supplied).



±2mm of the diameter of the circle is tolerable.

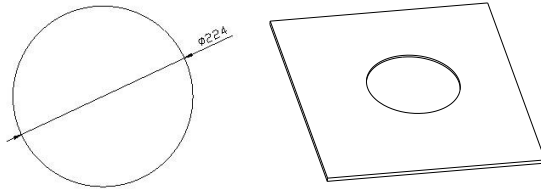

Figure 2-2 Draw and Cut Hole on the Ceiling

6. Connect the cables.

Make sure the video cable and control wire have been connected to the corresponding interfaces. Connect the power cable and the red LED indicator turns on when the power is on.



Please turn the power off after checking the speed dome.

7. Install the speed dome.

- (1) Loosen the two lock screws on both sides of the back box and make the locks in internal position, as shown in the following figure:

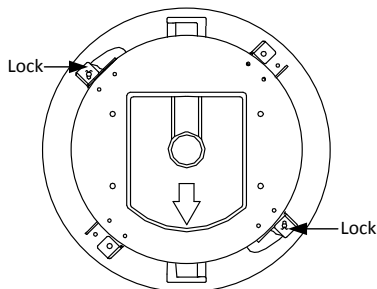

Figure 2-3 Locks and Lock Screws

- (2) Push the back box into the mounting hole in the ceiling
- (3) Tighten the lock screws with the screwdriver and the locks will automatically rotate outwards to secure the in-ceiling mount to the ceiling.

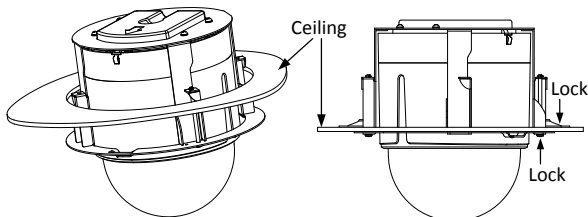

Figure 2-4 Install the back box

8. Install the trim ring.

- (1) Attach the trim ring to the lower dome and align the triangular notch of the trim ring with the arrow label on the in-ceiling mount.
- (2) After having firmly placed the trim ring to the ceiling, rotate the trim ring in the direction of arrow to secure the trim ring in place.



- Please remove the protective film on the lower dome after the installation is finished.
- In order to obtain clear video images, please wear the anti-static gloves when you install the speed dome.

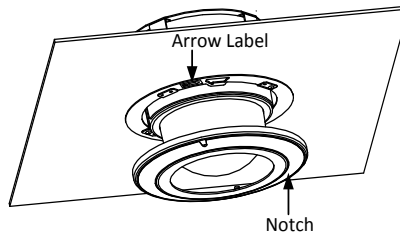

Figure 2-5 Install the Trim Ring

2.2 5-inch Speed Dome Ceiling Mounting Applications

Before you start:

The ceiling mounting is applicable to the indoor/outdoor solid ceiling construction. The followings are the mandatory precondition for ceiling mounting:

- The thickness of the ceiling must ranges from 5 to 40mm.
- The ceiling must be strong enough to withstand more than 4 times the weight of the dome and its accessories.

2.2.1 Removing the Mounting Bracket

It is required to modify the external structure of the in-ceiling mounting speed dome before the operation of ceiling mounting.

Steps:

1. Remove the 4 screws on the back box by a Phillips screwdriver.

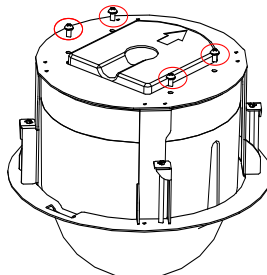

Figure 2-6 Remove 4 screws

2. Remove the in-ceiling mounting bracket.

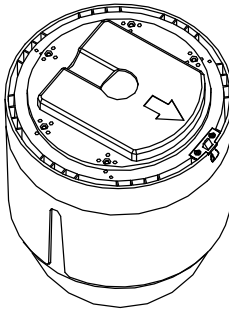

Figure 2-7 Remove the in-ceiling mounting bracket

3. Screw 4 bolts onto the back box by a Phillips screwdriver.

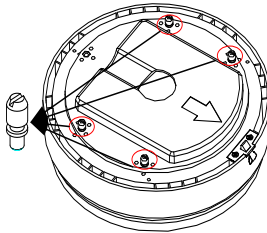

Figure 2-8 Install the bolts

2.2.2 Wiring

The cables of dome can be routed either from the top or the side of the back box. For the cables routed from the top of the back box, it is required to drill a cable hole in the ceiling.

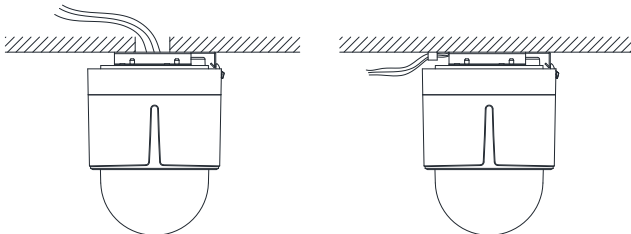

Figure 2-9 Cabling for Ceiling Mounting

2.2.3 Ceiling Mounting

Steps:

ST-HDC2IRPTZ QUICK START GUIDE

1. Rotate the lower dome counterclockwise to separate it from the back box. Refer to the Figure 2-1.
2. Remove the protective lens cover, foam and sticker from the dome drive.
3. Set the address and baudrate for the analog speed dome. Please refer to the *Section 1.2.1 5-inch Speed Dome Settings* for DIP switch settings.
4. Attach lower dome to the back box, and rotate clockwise to secure it.
5. Use the mounting base as a template to mark four screw holes onto the ceiling.
6. If you route cables from the top of the back box, mark the cable hole on the ceiling and drill a hole.

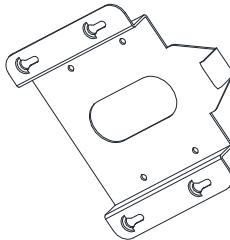

Figure 2-10 Mark the Screw Positions

7. Secure the mounting base to the ceiling with set screws.
 - If the speed dome is installed to the wooden wall, use the self-tapping screws to secure the mounting base.
 - If the dome is installed to the cement wall, drill three $\Phi 5$ mounting holes onto the wall according to the hole locations, and then insert the cement screws into the holes and finally use self-tapping screws to secure the mounting base to the wall.

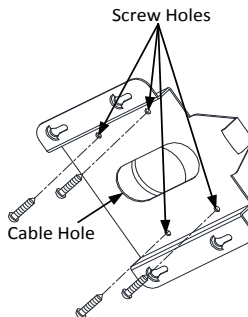

Figure 2-11 Secure the Mounting Base

8. Install the speed dome to the mounting base.
 - (1) Route the cables for the speed dome. Align the bottom of the speed dome with the mounting base.
 - (2) Line up the direction of arrow with the spring end of the mounting base.
 - (3) Push the speed dome upwards and then forwards in the direction of arrow. When the speed dome is placed in position, the spring will automatically snap into the lock clip firmly. Refer

to the following figure.

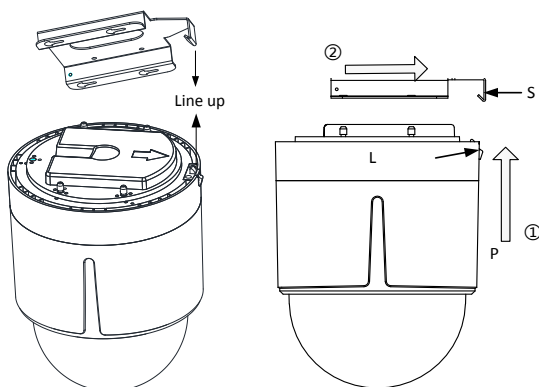

Figure 2-12 Attach the Back Box to the Mounting Base



- Please remove the protective film on the lower dome after the installation is finished.
- Do not touch the bubble of the lower dome directly by hand. The image blurs otherwise.

2.3 Mini Speed Dome In-ceiling Mounting Applications

2.3.1 Mini Analog Speed Dome In-ceiling Mounting

Before you start:

The in-ceiling mounting is applicable to the indoor ceiling construction. The following are the mandatory preconditions for mounting:

- The height of the space above the ceiling must be more than 250mm.
- The ceiling thickness must be between 5 and 40mm.
- The ceiling must be strong enough to withstand more than 4 times the weight of the dome and its accessories.

Steps:

1. Drill holes in the ceiling.
 - 1) Attach the drill template to the ceiling where you need to install the speed dome.
 - 2) Cut a hole and drill screw holes according to the drill template.



±2mm of the diameter of the circle is tolerable.

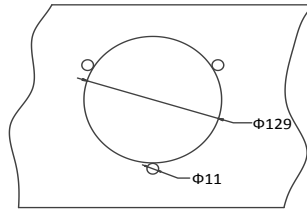

Figure 2-13 Drill Holes

2. Disassemble the speed dome.
 - 1) Loosen three screws as shown in the following figure.
 - 2) Remove the lower dome.
 - 3) Loosen three screws and remove the back box.
 - 4) Remove the protective lens cover, foam and sticker from the dome drive.

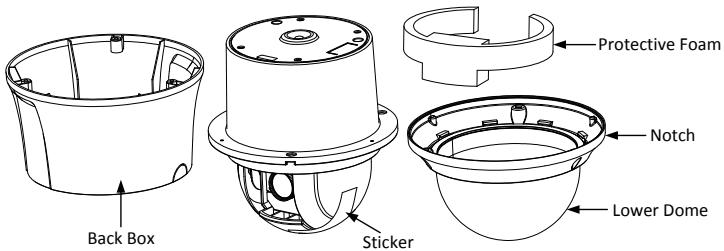

Figure 2-14 Disassemble the Speed Dome

3. Install the toggle bolts.
 - 1) Remove the toggle from the toggle bolt.
 - 2) Insert the bolts into the screw holes on the dome.
 - 3) Rotate the bolts through the screw holes.
 - 4) Reinstall the toggles as shown in Figure 2-15.

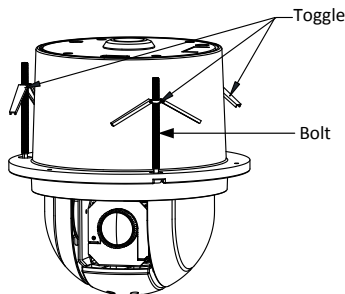

Figure 2-15 Install the Toggle Bolts

4. Align the toggle bolts with the screw holes on the ceiling.
5. Push the dome to the mounting hole on the ceiling.

6. Rotate the bolts again. The toggle will automatically rotate down to secure the dome to the ceiling.

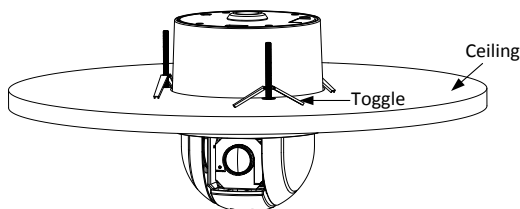

Figure 2-16 Install the Dome to the Ceiling

7. Secure the lower dome to the back box with three screws as shown in Figure 2-17.

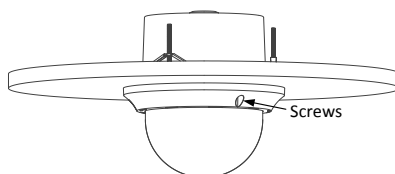

Figure 2-17 Install the Lower Dome

8. Route the cables through the ceiling for the speed dome. Please refer to the *section 1.1 Connecting the Cables* to connect the cables.

2.3.2 Mini IR Speed Dome In-ceiling Mounting

Before you start:

The in-ceiling mounting is applicable to the indoor ceiling construction. The following are the mandatory preconditions for mounting:

- The height of the space above the ceiling must be more than 250mm.
- The ceiling thickness must be between 5 and 40mm.
- The ceiling must be strong enough to withstand more than 4 times the weight of the dome and its accessories.

Steps:

1. Set the address, baudrate and protocol. For the detailed DIP switch settings, please refer to *Section 1.2.4 Mini Speed Dome Settings*.
2. Drill holes in the ceiling.
 - 1) Attach the drill template to the ceiling where you need to install the speed dome.
 - 2) Cut a hole and drill screw holes according to the drill template.



±2mm of the diameter of the circle is tolerable.

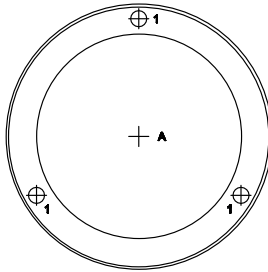

Figure 2-18 Drill Template

3. Route the cables through the ceiling for the speed dome. Please refer to the *section 1.1 Connecting the Cables* for connecting the cables.
4. Install the toggle bolts.
 - 1) Remove the toggle from the toggle bolt.
 - 2) Insert the bolts into the 3 screw holes on the dome.
 - 3) Rotate the bolts through the 3 screw holes.
 - 4) Reinstall the toggles as shown in Figure 2-19.

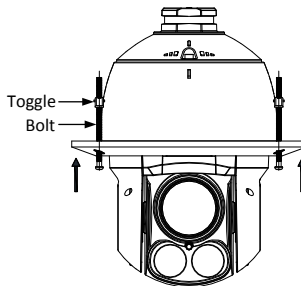

Figure 2-19 Install Toggle Bolts

5. Align the toggle bolts with the screw holes on the ceiling.
6. Push the dome to the mounting hole on the ceiling.

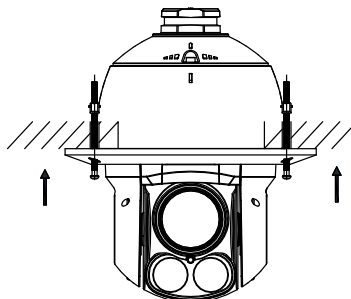

Figure 2-20 Push to the Mounting Hole

7. Rotate the bolts again. The toggle will automatically rotate down to secure the dome to the ceiling.

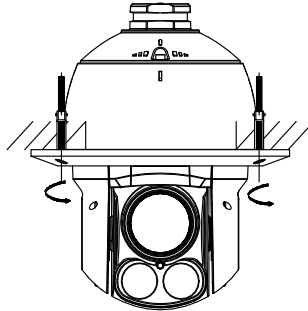

Figure 2-21 Install the Dome to the Ceiling

2.4 Mini Speed Dome Ceiling Mounting Applications

Before you start:

The ceiling mounting is applicable to the indoor/outdoor solid ceiling construction. The following are the mandatory preconditions for ceiling mounting:

- The ceiling thickness must be between 5 and 40mm.
- The ceiling must be strong enough to withstand more than 4 times the weight of the dome and its accessories.

2.4.1 Wiring

The cables of dome can be routed either from the top or the side of the back box, as shown in Figure 2-22. For the cables routed from the top of the back box, it is required to drill a cable hole in the ceiling.

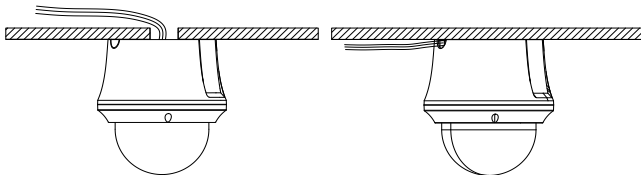

Figure 2-22 Cabling for Ceiling Mounting

2.4.2 Ceiling Mounting

Steps:

1. Drill Screw holes in the ceiling.
 - 1) Attach the drill template to the ceiling where you need to install the speed dome.

ST-HDC2IRPTZ QUICK START GUIDE

- 2) Drill screw holes and a cable hole (optional) according to the drill template.

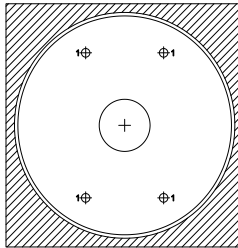

Figure 2-23 Drill Template

2. Disassemble the speed dome.
 - 1) Loosen three screws on the notch.
 - 2) Remove the lower dome.
 - 3) Remove the protective lens cover, foam and sticker from the dome drive as shown in Figure 2-24.

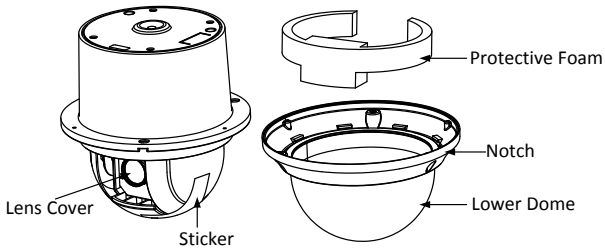

Figure 2-24 Disassemble the Speed Dome

3. Attach lower dome to the back box, and secure it with screws.
4. Align the ceiling mount with the screw holes on the drill template. Secure the ceiling mount to the ceiling with screws (supplied).

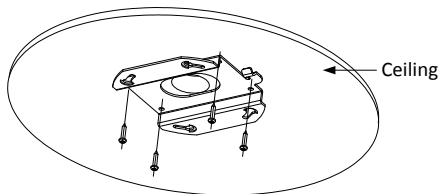

Figure 2-25 Install Ceiling Mount

5. Align the hook of the ceiling with unlock label on the speed dome.
6. Push the speed dome to the ceiling mount and rotate clockwise to secure it.

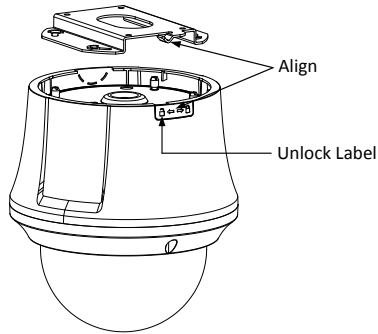

Figure 2-26 Install Speed Dome



- For cement ceiling mounting, you need to use the expansion screw to fix the mount. The mounting hole of the expansion pipe on the wall should align with the mounting hole on the mount.
- For wooden ceiling mounting, you can just use the self-tapping screw to fix the bracket.

3 Application and Operations

3.1 System Application

The device can be controlled through the back-end device or control software. The back-end device includes control keyboard, DVR (Digital Video Recorder), etc., and the control software includes client software. Here we take the connection of DVR as the example.

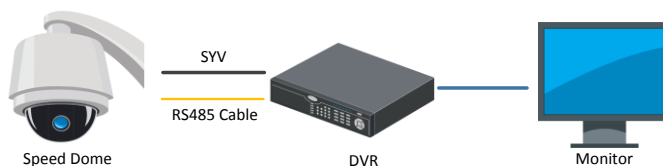

Figure 3-1 System Application



- If both the speed dome and the DVR support the coaxial function, the RS485 cable is not necessary.
- The HD-TVI video output can only be connected to specific HD-TVI DVR.

3.2 Basic Operations

Make sure the speed dome is connected properly, and the following basic operations are supported:

Panning and tilting:

Click the direction buttons to control the pan and tilt movement of the speed dome.

Zooming:

Click the **ZOOM+** and **ZOOM-** buttons to control the zooming.

Focusing:

Click the **FOCUS+** and **FOCUS-** buttons to adjust the focus.

Iris:

Click the **IRIS+** and **IRIS-** buttons to adjust the iris.

Preset control:

The speed dome supports the preset function, and the configurable preset range varies according to the control system. The system menu pops up after you call the No.95 preset

The main menu interface is shown as follows:

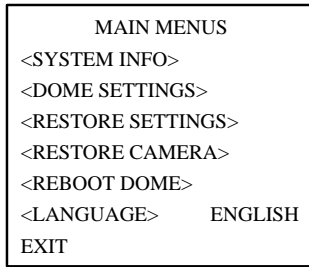

Figure 3-2 Main Menu



Refer to the user manual for the detailed instruction to set the speed dome.

3.2.1 Configuring Patrol

You can set the patrol function by the DVR and OSD menu, as well as the one-touch patrol can be realized.

- **Configuring Patrol by DVR**

Steps:

1. Enter the PTZ Control interface.

Menu>Camera>PTZ



Figure 3-3 PTZ Settings

2. Select patrol No. in the drop-down list of patrol.
3. Click the **Set** button to add key points for the patrol.

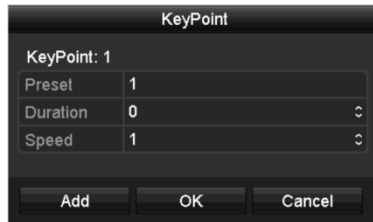

Figure 3-4 Key point Configuration

4. Configure key point parameters, such as the key point No., duration of staying for one key point and speed of patrol. The key point is corresponding to the preset. The **Key Point No.** determines the order at which the PTZ will follow while cycling through the patrol. The **Duration** refers to the time span to stay at the corresponding key point. The **Speed** defines the speed at which the PTZ will move from one key point to the next.
5. Click the **Add** button to add the next key point to the patrol, or you can click the **OK** button to save the key point to the patrol.

You can delete all the key points by clicking the **Clear** button for the selected patrol, or click the **Clear All** button to delete all the key pints for all patrols.

● **Configuring Patrol by OSD Menu**

Steps:

1. Call the preset 95 to enter the main menu and move the cursor to enter patrol configuration submenu:

MAIN MENU > DOME SETTINGS > PATROLS

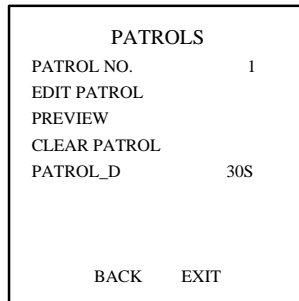

Figure 3-5 Patrol Configuration Menu

2. Choose the patrol number.
 - 1). Move the cursor to **PATROL NO.** and click **IRIS+** to enter edit mode.
 - 2). Click the up and down direction buttons to select the number of the patrol which is to be configured.
 - 3). Click **IRIS+** again to confirm the settings and exit edit mode of this column.



Up to 8 patrols can be configured.

3. Edit the patrol.

- 1). Move the cursor to **EDIT PATROL** and click **IRIS+** to enter edit mode.

NUM	PST	DWELL	SPEED
1	0	6	30
2	0	6	30
3	0	6	30
4	0	6	30
5	0	6	30
6	0	6	30
7	0	6	30
IRIS+ OK		IRIS- CANCEL	

Figure 3-6 Edit the Patrol

- 2). Click up/down direction buttons to choose the number and locate the preset to be edited.
 3). Click left/right direction buttons to position the cursor to the column of **PRESET**, **DWELL** and **SPEED**. You can click the up/down direction buttons to set the value of preset number, dwell time and patrol speed.



The presets you set for a patrol should be the ones that have been pre-defined by users. The dwell time (5-800 seconds selectable) is the time that the speed dome stays on a certain preset; the patrol speed (level 1-40 selectable) is the scanning speed the speed dome switching between the presets.

- 4). Follow the above steps to define the other presets for the selected patrol. You can configure up to 32 presets in sequence for a patrol. Press **IRIS+** to save the new settings or press **IRIS-** to cancel and return to the previous menu.
4. Call the defined patrol.

Back to the live view interface after you finish editing the patrol, and call the special presets to call the defined patrol. The presets 35~38 stand for patrol 1~4 and presets 102~105 stand for patrol 5~8.

● **Calling Quick Patrol**

The dome starts patrol from the predefined preset 1 to preset 32 in order after the park time. The undefined preset will be skipped.

Steps:

1. Set the preset 1~32 by DVR or OSD menu.
2. Call the preset 46 to start the quick patrol.

3.2.2 Configuring Park Actions

Purpose:

For some certain model of the speed dome, it can be configured to start a predefined park action (scan, preset, patrol and etc.) automatically after a period of inactivity (park time).

● **Configuring Park Actions by DVR**

Steps:

1. Click the button **PTZ** in the lower-right corner of the PTZ setting interface;
Menu>Camera>PTZ
2. Click the  button to show the one-touch function of the PTZ control.



Figure 3-7 PTZ Panel - One-touch

3. There are 3 one-touch park types selectable, click the corresponding button to activate the park action.

Park (Quick Patrol): The dome starts patrol from the predefined preset 1 to preset 32 in order after the park time. The undefined preset will be skipped.

Park (Patrol 1): The dome starts move according to the predefined patrol 1 path after the park time.

Park (Preset 1): The dome moves to the predefined preset 1 location after the park time.



The park time can only be set through the speed dome configuration interface, by default the value is 5s.

4. Click the button again to inactivate it.

● **Configuring Park Actions by OSD Menu**

Steps:

1. Call the preset 95 to enter the main menu and move the cursor to enter motion parameters setting submenu:
MAIN MENU > DOME SETTINGS > MOTION SETTINGS

MOTION	
AUTO FLIP	ON
PROPORTIONAL PAN	ON
PARK TIME	5
PARK ACT	NONE
SCAN SPEED	28
IMAGE FREEZE	OFF
DOME SPEED	6
BACK	EXIT

Figure 3-8 PTZ Configuration

2. Move the cursor to the **PARK TIME**, and set the value in the range from 5 to 720 seconds.
3. Move the cursor to the **PARK ACT**, and the action can be set as preset 1-8, pattern 1-5, patrol 1-10, pan scan, tilt scan, random scan, frame scan, panoramic scan, day mode, night mode, patrol-d or none.



If no control signal is received after the park time under the following circumstances, no park actions will be performed: in the process of performing dome actions by calling special presets.

4 Troubleshooting

4.1 Device Exceptions

Question

Why does the speed dome fail to start or repeatedly reboot? Why does the speed dome restart intermittently when controlling PTZ, calling presets or turning on the infrared lights of the IR dome at night?

Answer

- Check the supply voltage of the dome. Ensure the supply voltage to meet the power requirements of the speed dome. The nearest power supply is recommended.
- Check whether the diameter of the power wire meet the standards.

4.2 PTZ Control Exceptions

Question

The speed dome cannot do PTZ control but can do zoom control.

Answer

- For the 5 inch speed dome, you need to remove the protective sticker and foam of the camera module by opening the bubble, correctly install the speed dome again and then wire up.
- For IR speed dome, please remove the protective sticker and then wire up.

Question

Neither zoom control nor PTZ control is available for the speed dome.

Answer

- Check the supply voltage of the dome. Ensure the supply voltage to meet the power requirements of the speed dome. The nearest power supply is recommended.
- Check whether the diameter of the power wire meet the standards.

4.3 Other Questions

Question

The preview image of the speed dome is not clear.

Answer

- Please check whether the protective film of the bubble has been removed.
- Please check whether there are foreign objects on the bubble or the lens.
- Please check where there are obstructions such as spider web nearby.
- Open the bubble and check whether the lens cover has been removed.
- Restore the device to the default settings. Call the preset 95 to enter the OSD menu and select the **RESTORE CAMERA**.

Question

For the IR speed dome, the image is abnormal white when the IR light is turned on in the night.

Answer

- Please check whether there are obstructions near the lens, e.g. wall, leaf, spider web, cables, etc., which will cause the over-exposure due to the IR light reflection. Clear the obstructions if necessary.

Question

The speed dome cannot focus when working in indoor conditions.

Answer

- Please restore the device to the default to exclude the factor of incorrect calibration.
- Reduce the minimum focusing distance of the device by configuring the image settings through the OSD menu.

For further assistance and troubleshooting, please contact SecurityTronix tech support at: **(800) 688-9282**, press **3** for Tech Support, then press **2** for CCTV.

SECURITYTRONIX 1-Year Limited PTZ Camera Warranty

Securitytronix. (the "Company") warrants to the Original Purchaser that the PTZ Camera is free from defects in workmanship or material under normal use. This warranty starts on the date of shipment of the hardware to the Original Purchaser. During the warranty period, the Company agrees to repair or replace, at its sole option, without charge to Original Purchaser, any defective component in the PTZ Camera. To obtain service, the Original Purchaser must return the PTZ Camera to the Company properly packaged for shipping. All defective products must be returned to the Company within thirty (30) days of failure. Products must be returned with a description of the failure and Return Merchandise Authorization (RMA) number supplied by the Company. To receive a RMA number and a return shipping address on where to deliver the hardware, call 610-429-1821. The shipping, and insurance charges incurred in shipping to the Company will be paid by Original Purchaser, and all risk for the hardware shall remain with the Original Purchaser until such time as Company takes receipt of the hardware. Upon receipt, the Company will promptly repair or replace the defective unit, and then return said unit to Original Purchaser, shipping prepaid. The Company may use reconditioned or like-new parts or units, at its sole option, when repairing any hardware. Repaired products shall carry the same amount of outstanding warranty as from original purchase. Any claim under the warranty must include dated proof of purchase or invoice. In any event, the Company's liability for defective hardware is limited to repairing or replacing the hardware. This warranty is contingent upon proper use of the hardware by Original Purchaser and does not cover: if damage is due to Acts of God (including fire, flood, earthquake, storm, hurricane or other natural disaster), accident, unusual physical, electrical, or electromechanical stress, modifications, neglect; misuse, operation with media not approved by the Company, tampering with or altering of the hardware, war, invasion, act of foreign enemies, hostilities (regardless of whether war is declared), civil war, rebellion, revolution, insurrection, military or usurped power or confiscation, terrorist activities, nationalization, government sanction, blockage, embargo, labor dispute, strike, lockout or interruption or failure of electricity, air conditioning, or humidity control, internet, network, or telephone service The warranties given herein, together with any implied warranties covering the hardware, including any warranties of merchantability or fitness for a particular purpose, are limited in duration to one year from the date of shipment to the Original Purchaser. Jurisdictions vary with regard to the enforceability of warranty limitations, and you should check the laws of your local jurisdiction to find out whether the above limitation applies to you. The Company shall not be liable to your for loss of data, loss of profits, lost savings, special, incidental, consequential, indirect, or other similar damages arising from breach of warranty, breach of contract, negligence, or other legal action even if the Company or its agent has been advised of the possibility of such damages, or for any claim brought against your by another party. Jurisdictions vary with regard to the enforceability of provisions excluding or limiting liability for incidental or consequential damages. You should check the laws of your local jurisdiction to find out whether the above exclusion applies to you. This warranty allocates risks of product failure between Original Purchaser and the Company. The Company's hardware pricing reflects this allocation of risk and the limitations of liability contained in this warranty. The warranty set forth above is in lieu of all other express warranties, whether oral or written. The agents, employees, distributors, and dealers of the Company are not authorized to make modification to this warranty, or additional warranties binding on the Company. Accordingly, additional statements such as dealer advertising or presentations, whether oral or written, do not constitute warranties by the Company and should not be relied upon. This warranty gives you specific legal rights. You may also have other rights which vary from one jurisdiction to another.